

New Jersey Insurance Underwriting Association

Administrator of:

- ◆ **Property FAIR Plan**
- ◆ **Crime Indemnity Plan**
- ◆ **Windstorm Market Assistance Plan**

NJIUA Producer Guidelines

Section

A. Table of Contents

B. Introduction

- History
- Purpose and Mission
- Conformity to Statute
- How to Contact NJIUA

C. General Rules

- Producers
- Commission
- Applicants
- Insurable Property
- Property Not Insurable
- Rates
- When Does Coverage Begin
- Policy Period
- Mine Subsidence
- Terrorism
- Actual Cash Value
- Inspections
- Claim Reporting
- Declination
- Policy Cancellation
- Producer Issued Endorsements

D. Dwelling Business

- Eligibility Criteria
- Maximum Limits
- Covered Perils
- Minimum Premium
- Deductibles
- Coinsurance
- Vacant or Unoccupied Property
- Seasonal Property
- Property Under Construction
- Property Under Renovation
- List of Frequently Used Policy Forms
- Applications and Questionnaires

Section

E. Commercial Business

- Eligibility Criteria
- Maximum Limits
- Minimum Premium
- Covered Perils
- Deductibles
- Coinsurance
- Vacant or Unoccupied Property
- High Value Property
- Policy Forms
- Applications

F. Crime Business

- Applicants
- Coverage
- Maximum Limits
- Deductibles
- Premium Calculation
- Applications

G. Special Situations

- Vacant or Unoccupied Property
- Fungi, Wet or Dry Rot or Bacteria Options
- Terrorism Coverage
- Hurricane Damage Mitigation Program

H. WindMAP

- WindMAP Application Instructions
- Coastal Zip Codes
- Participating Companies

I. Frequently Asked Questions

B. Introduction

History of the New Jersey Insurance Underwriting Association

NJIUA was created as a legislative outgrowth of the Kerner Commission on Civil Rights, following riots in Newark, Detroit and Washington, D.C. during the summer of 1967.

The Congressional sub-committee on insurance, chaired by Governor Hughes of New Jersey, found that lack of insurance was a contributing factor to high unemployment and lack of development in urban areas. The Commission recommended that states make insurance available in urban areas, and 29 states established FAIR Plans to provide **essential property insurance**.

The Association was organized in 1968, pursuant to Chapter 129, laws of New Jersey. All authorized insurance companies writing property insurance within New Jersey on a direct basis are members of the Association. The enabling Statute 17:37A 1-22 provides that:

Essential property insurance is necessary to attract and retain private capital, supply needed goods and services, expand job opportunities, enable homeowners to obtain financing for purchase and improvement of their property, and promote orderly community development.

NJIUA Mission and Purpose

Today, the mission of NJIUA is to provide essential property insurance to applicants who cannot secure coverage in the voluntary market. As the market of last resort, we will not seek customers, and will not encourage producers to place business with us. We will be accessible, and easy to do business with, for those who must use the residual market. We will provide accurate information and timely response. We will settle legitimate claims promptly and fairly, while resisting fraudulent activities.

Neighborhood area, location, or environmental hazards beyond the control of the property owner or applicant will not be considered in determining insurability. However, property with characteristics of ownership, condition, occupancy, or maintenance that violate public policy, or are otherwise not contributing to community development, may be deemed uninsurable, until such conditions are corrected.

Conformity to Statute

NJIUA was created by statute, and all activities of the Association are governed by that legislation under a formal Plan of Operation approved by the Department of Banking and Insurance.

The purpose of this Producer Guide is to provide useful instructions to producers who need to place business with the Association. As a guide, any interpretations must be consistent with the Statute and approved Plan of Operation.

How to Contact NJIUA

744 Broad Street
Newark, NJ 07102-3881

Our Website is www.njiua.org.

Our telephone number is (973) 622-3838

The automated answer feature can be used to access customer service staff:

WindMAP		Touch 2
Claim Questions		Touch 3
Policy Questions	Mortgagee	Touch 4
	Producer	Touch 7
	Out of State	Touch 8

WindMAP or Policy Information	Fax (973) 297-1133
Underwriting Fax	(973) 297-5032

Claim Information	Fax (973) 297-5033
Toll Free Number	1-866-654-7526

Underwriting/Customer Service Representatives

Agency Location	Underwriter	Customer Service Representative
Camden, Salem, Gloucester	Diane Young-ext. 6033	Ruth Williams- ext. 6037 Kamie Daniel –ext. 6030 Felicia Dubose-ext. 6025
Essex, Hudson & Bergen	Maritoni Yumang-ext. 6017	Ibis Zafra-ext.6011 Faziah Mangar ext.6012
Atlantic, Burlington, Cape May, Cumberland, Middlesex, Monmouth, Ocean	Dianna Anthony-ext.6043	Indra Ramos-ext.6034

Hunterdon, Mercer, Morris Jennifer Adi-Darko-ext-6024
Passaic, Somerset, Sussex,
Union, Warren

Producer Guidelines
Latisha Elam-ext.-6018

How to Contact NJIUA

Continued

Officers of the Association

Jerry Warner	President
Theodore Green	Controller, Vice President
Steven Mutterperl	Underwriting Vice President
Alan E. Jankoski	Claims Vice President
Israel M. Popack	Chief Information Officer

C. General Rules

The following are General Rules that apply to the Dwelling and Commercial lines of business.

Producers

The Association has no agents. The use of the term “Agent” does not grant any contract relationship, either actual or implied, between the Association and any individual or entity.

1. All agents or brokers licensed to do business in the state of New Jersey are eligible to place business with the New Jersey Insurance Underwriting Association.
To register with NJIUA, the following forms are required:
 - a) A copy of producer license issued by the state of New Jersey.
 - b) A completed Request for Taxpayer Identification Number and Certification – **W9**.
Send the documents to: NJIUA
744 Broad Street
Newark, NJ 07102
2. Any licensed property insurance producer is acting as the designated representative of the applicant or insured, and NOT as an agent of the Association.
3. The producer cannot bind the Association to any coverage.
4. The producer cannot issue a policy, binder, cancellation notice, or coverage change endorsement; nor assign any loss on behalf of the Association.
5. The Association does not recognize any ownership or rights of producers related to renewal of expiring policies.

Commission

- 10% is paid to producers for Dwelling and Commercial Property business.
- 15% is paid to producers the first year for Crime business (10% for renewal years)

Installment Payment Plan – Renewals Only

Premium payments can be made in two equal installments. The first payment is due on or before the renewal date and the second payment is due 90 days later. A \$5.00 service fee will apply to each payment.

Applicant

Any person having an insurable interest in the property to be insured may complete an application. Applicant may apply directly to the Association, or through a licensed producer authorized by the applicant. Partnerships, corporations or other legal entities must disclose

information about principal owner, and other owned properties. Refer to the Applications section of this guide for current forms required.

Before applying to the Association, all applicants must make a diligent effort to secure coverage in the voluntary insurance market.

Insurable Property

Any real property or personal property located within the state of New Jersey is potentially insurable.

Certain types of property or properties with certain conditions are not insurable with the Association. Refer to the remaining sections of this manual for more specific guidelines.

Properties Not Insurable

- a. Automobile risks or automobile property.
- b. Farm risks or property used for agricultural pursuits.
- c. Buildings on which property taxes are unpaid for two or more quarters.
- d. Buildings that are vacant or unoccupied and accessible to unauthorized persons.
(Refer to **Section G. Vacant or Unoccupied Property.**)
- e. Buildings with any of the rental units in the building being vacant or unoccupied and accessible to unauthorized persons.
- f. Buildings that have an exceptional degree of hazard, such as the following:
 - *Buildings previously damaged, and the damages are not repaired within a reasonable time.*
 - *Buildings in danger of collapse because of dilapidated or serious structural conditions.*
 - *Buildings used for storage of flammable materials.*
 - *Buildings that have been condemned.*
- g. Buildings that have characteristics of ownership, condition, occupancy or maintenance that violate public policy, such as the following:
 - *Buildings from which fixed and salvageable items have been or are being removed.*
 - *Failure to furnish heat, water, sewer or public lighting.*
 - *Failure to correct conditions dangerous to life, health or safety, or violations of applicable laws.*

- *When there is reasonable knowledge and belief that the property is endangered and is not reasonably protected from possible arson for profit.*
 - *The building is used for selling or using drugs or narcotics.*
- h. The insured has been indicted for or convicted of arson or burning with intent to defraud, or there is evidence of incendiaries or attempt thereof by the insured or representative of the insured.

This list describes conditions or circumstances that make the property uninsurable until they are corrected. There may be other conditions, discovered upon inspection or investigation, which make the property uninsurable until improvements are made. The insured and producer will be notified of the conditions that require modification.

Rates

- Rates in use by the Association are approved by the Department of Banking and Insurance.
- Rates for Dwelling Fire business are available through Electronic Insurance Office (609) 267-1992. The EIO worksheet should accompany all dwelling fire applications. Rates for Dwelling Crime business are included in the Crime section of this manual. Producers are encouraged to rate dwelling business to provide quotations to their customers.
- Commercial Fire and Commercial Crime rates are not available to producers. NJIUA will provide premium quotations upon receipt of the completed application.

When Does Coverage Begin?

For most applicants coverage begins upon receipt by the Association of the fully completed and signed application, plus any required supplemental forms, with full payment of the net annual premium.

“Receipt by the Association” means:

- If sent by U.S. Certified Mail, at 12:01 AM on the next day following the USPS cancellation date.

- If sent by regular mail, at 12:01 AM on the day the application is actually received in the Association Office.
- If personally delivered to the Association Office by the Applicant, at 12:01 AM on the day AFTER the date delivered.

For applications on property that may be uninsurable, as defined in this guide, coverage cannot begin until after an inspection is completed. This includes all vacant or unoccupied properties, and those previously damaged but not yet repaired.

Facsimile transmission of applications is not permitted to establish when coverage begins.

Incomplete applications will be returned, and may cause delay in establishing when coverage begins.

Hurricane Advisory

The Association will not accept applications for any new policy, nor any request for increased coverage on existing policies when either a hurricane watch or hurricane warning is in effect for any portion of the state of New Jersey.

Suspension of New Business during Hurricane Period

During the period of suspension, applications for any new policy or any request for increased coverage on existing policies will not be accepted. We will return an acknowledgement that the application was received, stating that coverage is not in force. The suspension will remain in place for 24 hours after the National Weather Service has removed the hurricane watch or warning.

Policy Period

The policy period is one year and policies are not automatically continued or renewed. Upon approval of the new business application, NJIUA will send the producer the policy documents for the insured and a producer copy of the declaration page. Mortgagee copies of the declaration page when applicable are sent directly to the mortgage company through a third party vendor. The producer is responsible for sending the documents to the insureds.

Approximately 60 days prior to a policy's expiration date, a Notice of Expiration will be sent directly to the insured, producer and mortgagee when required. Full annual premium or the first installment payment plus payment fee must be received by NJIUA before coverage is renewed.

Mine Subsidence

Coverage is provided on all Dwelling and Commercial policies for a flat charge of \$5 per policy. For details regarding this coverage, refer to the policy forms section of this guide.

Limited Fungi, Wet or Dry Rot, or Bacteria Coverage

Coverage is provided for Dwelling Fire and Commercial Standard property business when the fungi, wet rot, dry rot or bacteria is a result of a covered cause of loss. *See Section G. Special Situations* for additional information.

Coverage for Certified Acts of Terrorism

Coverage is provided in accordance with the federal Terrorism Risk Insurance Program Reauthorization Act of 2007 for commercial lines and one to four family tenant occupied dwellings. *See Section G. Special Situations* for rejection of offer for Terrorism Coverage, Commercial Lines only.

Actual Cash Value (ACV)

DP 1 Basic Form policies provide coverage on an actual cash value basis. Replacement cost coverage is not available on the DP 1 form.

By case law, New Jersey is considered a Broad Evidence state, and many factors could potentially affect the determination of ACV.

Such factors might include:

- Assessed value of the improvement to the land.
- Market value of the building, less land.
- Replacement cost of the building less physical depreciation.
- Three year rental income from the property.
- The potential for alternative uses of the building.
- Obsolescence factors such as cost of upgrading to meet current building codes.

The principle of indemnity underlies any determination of ACV. Insurance recovery for a property loss should correspond to the actual financial loss sustained by any insured. The insured should not benefit from the loss.

Producers should assist the insured in establishing and maintaining appropriate insurable property values.

Replacement Cost Coverage

DP 2 Broad Form policies contain the replacement cost coverage claim settlement option on building coverage provided the structure is insured to at least 80% of the calculated replacement cost value. An automatic value up at renewal will be applied when warranted to keep pace with increased building costs. **Not all applicants will qualify for DP 2 coverage.**

The following properties are not eligible for the DP 2 program:

- Vacant dwellings
- Dwellings attached or adjacent to a vacant structure
- Mobilehomes
- Fire coverage only requested
- Coverage A below 80% of replacement value
- 2 or more fire losses within a 5 year period
- 2 or more water losses within a 5 year period
- Flat roof not updated/replaced within the last 10 years

Note: Properties not eligible for DP 2 Broad Form coverage may still be eligible for coverage under the DP 1 Basic Policy.

Inspections

Inspections are conducted to confirm information provided on the application, or to verify insurability of property. There will be no cost to the applicant for any inspection.

The Association requires inspections of both the interior and exterior of the property. Providing an accurate contact number on the application is essential for scheduling the inspection appointment.

Claim Reporting

All claims must be reported to NJIUA at:

744 Broad Street
Newark, NJ 07102
Phone: (973) 622-3838
Fax: (973) 645-0269

- Please use the ACORD Property Loss Notice for reporting claims. Fax submission of the ACORD form is acceptable.
- Producers cannot assign claims to adjusters.
- To report a claim through the internet visit our website at www.njiua.org and click on the claims tab. This will take you to an online claim report form.

Declination

Underwriting

The Association may deny an application and decline to issue a policy to any applicant if the property is not insurable. (Refer to Uninsurable Property section of this guide). A copy of the declination will be mailed to both the applicant and the producer.

Quote

The Association may decline an application when a formal premium quote has been issued to an applicant and payment for the policy is not received within 30 days from the quote date.

Financial

The Association may decline coverage for non-payment of the full annual premium or the selected installment payment option. Prior to such declination, a premium due notice will be issued, requesting full payment of the premium within 13 days. If the additional premium due is not paid, the application will be declined and any partial premium payment will be returned.

Policy Cancellation

Cancellation by the Association

When a property is found to be not insurable, a notice of cancellation will be issued, informing all parties listed on the policy of the reasons for the cancellation, and the measures required to make the property insurable.

The Association may cancel a policy with 30 days notice or, if conditions warrant, a Short Notice cancellation with 10 days notice.

Included with the cancellation notice is a statement informing the applicant of his right to appeal the decision of the Association, and the method to initiate an appeal.

Cancellation Requested by the Producer or Insured

The original policy or a completed Cancellation Request/Policy Release (ACORD Form 35C) should be submitted to request cancellation.

Requests for cancellation to be effective more than 60 days prior to the date of request should be accompanied by appropriate documentation. All cancellations are computed pro-rata and any unearned premium, net of commissions, will be refunded.

The producer must return any unearned commission.

Cancellation Requested by Premium Finance Company

If the premium finance company requests cancellation, unearned premium will be returned to that company.

The producer must return any unearned commission.

Producer Issued Endorsements

Producers should issue endorsements to make only the following changes:

- A. To correct the spelling of the named insured.**
- B. To correct the spelling of the mailing address.**
- C. To make mortgagee changes.**

Use the Acord Form and send one legible copy to the Association.

All other changes must be submitted to the Association for prior approval using a *Policy Change Request* form NJ-3. Producers interested in submitting endorsement requests through the internet should contact the Association for further instructions.

Requests for additional coverage can be accompanied by a check for the proper additional premium (net) for the unexpired term of the policy or can be billed after the change has been made. Documentation in the form of mortgage company requests, documentation of current market values, evidence of assessed value or copies of contracts or bills for recent improvements are required to support a request for an increase in coverage that is above 10% of the current coverage amount.

The minimum premium charge for additional coverage by endorsement is \$5.00 (gross).

D. Dwelling Business

Eligibility Criteria

- One, two, three or four family **private dwellings – DP 1 and DP 2 Forms**
- **Personal property (Contents)** usual or incidental to the occupancy of the dwelling-
DP 1 Only.

NOTE: For coverage of real property (building) for rooming houses, boarding houses or apartment houses, see *E. Commercial Business* section.

Maximum Limits – DP 1 and DP 2.

- Real Property (Building).....**\$600,000 – Maximum Per Location**
- Personal Property (Contents)

If the Association is providing the building coverage.....**Up to 50% of the Building Limit**
- **Maximum of \$300,000**

If the Association is not providing the building coverage.....**\$50,000 – Maximum Per Location**

The Maximum coverage per Location is \$900,000

Covered Perils – DP 1 and DP 2.

Direct loss to property caused by:

- Fire, Lightning,
- Explosion, Wind, Hail, Smoke, Aircraft, Vehicles, Riot or Civil Commotion,
- Vandalism or Malicious Mischief
- Mine Subsidence

ADDITIONAL DP 2 Broad Form Covered Perils

- Falling Objects
- Damage by Burglars
- Weight of Ice and Snow
- Volcanic Eruption
- Accidental Discharge of Water or Steam
- Freezing

- Sudden and Accidental tearing Apart, Cracking or Bulging

The Association does not provide:

- Flood coverage or Earthquake coverage
- Liability coverage

NOTE: Theft coverage can be added by endorsement to DP 1 and DP 2 policies. Coverage can be written for owner occupied dwellings for on premise contents coverage only. One prior theft loss is acceptable . Limits are in \$1000 increments from \$1,000 to \$20,000.

Minimum Premium

The annual minimum premium for the dwelling policy is \$50.

Deductibles

A minimum all perils deductible of \$500 applies to all policies.

In the coastal areas, a larger all perils deductible, and a special hurricane deductible may apply. Refer to chart below using property zip code and distance from the ocean.

COASTAL GROUP #1 ZIP CODES

07002	07713	07753	08248	08739
07008	07715	07755	08400	08740
07036	07716	07756	08403	08750
07064	07717	07757	08404	08753
07077	07718	07758	08405	08754
07201	07719	07760	08411	08755
07202	07720	07762	08721	08756
07206	07721	07764	08723	08757
07302	07723	08005	08724	08758
07304	07730	08050	08730	08832
07305	07732	08087	08731	08861
07306	07735	08092	08732	08862
07709	07737	08212	08734	08878
07711	07748	08223	08736	08879
07712	07750	08230	08738	

- More than two (2) miles from the ocean or bay as measured at mean high tide.
3% Hurricane Deductible with a \$500 All Perils Deductible.

- Between one (1) and two (2) miles from the ocean or bay as measured at mean high tide. 3% Hurricane Deductible with a \$1,000 All Perils Deductible.
- Within one (1) mile or less from the ocean or bay as measured at mean high tide. 4% Hurricane Deductible with a \$1,000 All Perils Deductible.

NOTE: If the insured property is located in a zip code 08050, 08731 or 08758 and over five (5) miles from the ocean as measured at mean high tide, only the \$500 All Perils Deductible will apply.

Deductibles

COASTAL GROUP #2 ZIP CODES

07734	08202	08243	08402	08742
07740	08203	08247	08406	08751
08006	08204	08260	08735	08752
08008	08226	08401		

- **5% Hurricane Deductible with a \$1,500 All Perils Deductible.**

Hurricane Damage Mitigation Program

Policyholders in the 116 coastal area zip codes may reduce the hurricane deductible if the insured location has been equipped to resist damage from hurricanes. Form HD 99-03, Hurricane Damage Mitigation Certification. *Refer to Section G* for details of the program.

Coinsurance

The DP 1 Basic Policy form in use by the Association does not contain a coinsurance clause. The DP 2 Broad Form policy contains an 80% coinsurance clause.

Vacant or Unoccupied Properties

The policy forms used by the Association suspend coverage if a property is Vacant or Unoccupied, and defines those terms for the purpose of the coverages provided. Refer to *Frequently Used Forms* included at the end of this section for details.

See *Section G. Special Situations* for the NJIUA Standards for the Protection of Vacant Properties.

Seasonal Properties

Property described as seasonal means it is continuously unoccupied for a period of three or more consecutive months. A property is not considered vacant during its normal period of seasonal unoccupancy.

Property Under Construction

Property under construction means new from the foundation or “ground up” construction. It does not apply to an existing building undergoing remodeling or renovation. A property under construction is not considered vacant during the construction period.

Property Under Renovation

Property under renovation means an existing building is undergoing remodeling, renovation, or repair. A property under renovation is considered vacant unless occupied by the insured throughout the renovation period.

Dwelling Fire

Frequently Used Policy Forms, Applications and Questionnaires

	Form	Edition
Policy Jacket	NJ 2J	8 97
Dwelling Policy	DP 00 02	12 02
Dwelling Policy	DP 00 01	07 88
Amendatory Endorsement	NJ 01 29	2 2000
Mandatory Mine Subsidence Coverage Endorsement	NJ MS	4 95
Vacant / Unoccupied Property Restriction	VP 00 01	02 2000
Hurricane Deductible Endorsement	HD 0405	01 2004
Hurricane Damage Mitigation Program	HD 99-03	03 99
Limited Fungi, Wet or Dry Rot, or Bacteria Coverage	DP 04 22	04 02
Cap on Losses from Certified Acts of Terrorism Disclosure	DP 05 38	06 08
Cap on Losses from Certified Acts of Terrorism	DP 05 37	06 08

Continued

Frequently Used Policy Forms, Applications and Questionnaires

	Form	Edition
New Jersey Insurance Underwriting Association Dwelling Fire Application <ul style="list-style-type: none">• Required for new dwelling business.	Acord 67	NJ (2002/07)
Vacant / Unoccupied Property Supplemental Application <ul style="list-style-type: none">• Required on any property that is vacant or unoccupied, including those under renovation, or for sale or rent.	VP 00 03	(02-2000)
Supplementary Corporate Questionnaire <ul style="list-style-type: none">• Required if the insured is a corporation, holding company or other fictitious entity.	NJ-1A	(09-87)
Producer Endorsement <ul style="list-style-type: none">• Issued by producer to correct spelling of insured or mailing address.	NJ-PE-77	(07-2000)
Policy Change Request <ul style="list-style-type: none">• Used to request other changes such as limits or occupancy.	NJ-3	(09-94)

Cancellation Request / Policy Release

Acord 35 (01/97)

- Used to cancel a policy by Insured's Request.

Water Exclusion Endorsement

DP 16 09 (01 09)

Required for new and renewal business

E. Commercial Business

All commercial applications require the additional completion of the **COMMERCIAL UNDERWRITING QUESTIONNAIRE** Form NJ 1B

Commercial Eligibility Criteria

All real property, other than 1 - 4 family dwellings, farm property and auto risks, is eligible for the Commercial program.

Maximum Limits

- Commercial BUILDING Coverage
 - Fire Resistive Construction \$1,100,000 per location
 - Ordinary Masonry Construction \$ 750,000 per location
 - Frame Construction \$ 500,000 per location

- Commercial CONTENTS Coverage
 - Fire Resistive Construction \$ 400,000 per location
 - Ordinary Masonry Construction \$ 250,000 per location
 - Frame Construction \$ 250,000 per location

Notes:

1. The maximum commercial **contents** limit may be doubled if the Insured is the **ONLY** commercial occupant at the insured location.

2. Any Applicant may make a specific request for insurance in excess of the applicable limit, in writing, to the Association, with a copy to the Commissioner. The Underwriting Committee may approve such additional amount of insurance as it may deem proper, but in no event shall the total amount of insurance exceed \$1,500,000.

The Maximum coverage per location is \$1,500,000.

Covered Perils

Direct loss to property caused by:

- Fire, Lightning, Sprinkler Leakage, Volcanic Eruption, Sinkhole Collapse
- Explosion, Wind, Hail, Smoke, Aircraft, Vehicles, Riot or Civil Commotion
- Vandalism or Malicious Mischief
- Mine Subsidence

The Association does not provide:

- Broad perils such as water damage or freezing
- Flood coverage
- Liability coverage
- Theft coverage (refer to *Section F. Crime Business*)

Minimum Premium

- The annual minimum premium for the commercial policy is \$100.

Deductibles

- \$500 minimum deductible applies to all Commercial Policies.
- \$1,000 deductible is available upon request, or may be imposed by the underwriter.

Coinsurance

On Commercial Property, the policy form in use by the Association contains an 80% coinsurance clause.

Vacant Properties

The policy forms used by the Association suspend coverage if a property is Vacant or Unoccupied, and defines those terms for the purpose of the coverages provided. Refer to *Frequently Used Forms* included at end of this section for details. VP 003 (02/ 2000)

See *Section G. Special Situations* for the NJIUA Standards for the Protection of Vacant Properties.

High Value Commercial Property

If the amount of insurance at any one location is \$400,000 or more, additional information must accompany all new and renewal applications. The producer must provide copies of the declinations from admitted companies, plus the insured's most recent financial statement.

Commercial Business

Frequently Used Policy Forms

	Form	Edition
Policy Jacket	NJ-2J	8 97
Standard Property Policy	CP 00 99	10 91
Amendatory Endorsement	NJ CP 520	11 89
Mandatory Mine Subsidence Coverage Endorsement	NJ MS	4 95
Cap on losses From Certified Acts of Terrorism	IL 09 52	03 08
Terrorism Risk Insurance Act Disclosure / Rejection Form	TRIA DISC	02 08
Exclusion of Certified Acts of Terrorism	IL 09 53	01 08
Limitations on Fungi, Wet Rot, Dry Rot and Bacteria Endorsement	CP 0171	09 02

COMMERCIAL BUSINESS

Form Edition

Application For Inspection and Insurance

Required for new and renewal commercial business.

Acord 68NJ (2003/7)

Commercial Underwriting Questionnaire

Required on all commercial business.

NJ-1B (5-93)

Supplementary Corporate Questionnaire

Required if the insured is a corporation,
holding company or other fictitious entity.

NJ-1A (9-87)

Water Exclusion Endorsement

Required for new and renewal business.

CP 10 32 (08 08)

F. Crime Business

A. Applicants

Any person unable to obtain crime insurance may apply to the New Jersey Insurance Underwriting Association for basic crime coverage.

B. Coverage

Basic Crime Indemnity coverage is available. Basic Crime Indemnity means the coverage provided by the standard policy forms listed below. Producers must refer to policy forms for property exclusions or sub-limits.

C. Maximum Limits

a. Residence Burglary and Robbery	\$15,000
b. Storekeeper's Burglary & Robbery	\$ 1,000
c. Office Burglary and Robbery	\$ 1,000
d. Mercantile Robbery	\$ 1,000 inside \$ 1,000 outside \$ 5,000 outside when messenger accompanied by armed guard
e. Mercantile Safe Burglary	\$ 5,000
f. Mercantile Open Stock Burglary	\$10,000 or the coinsurance limit, whichever is greater

D. Deductible

The minimum deductible is the greater of \$100 or 5% of the policy limits.

E. Premium Determination

Premium for the Residence Burglary and Robbery policy may be determined from the chart on the following page. For all other policies, submit completed application to NJIUA.

Residence Burglary and Robbery Policy Premium Table

<u>Amount of Insurance</u>	<u>Annual Premium</u>
\$1,000	\$50
1,500	53
2,000	56
2,500	60
3,000	63
3,500	66
4,000	69
4,500	72
5,000	75
5,500	78
6,000	82
6,500	85
7,000	88
7,500	92
8,000	95
8,500	98
9,000	101
9,500	105
10,000	108
10,500	111
11,000	114
11,500	118
12,000	121
12,500	124
13,000	127
13,500	131
14,000	134
14,500	137
15,000	140

G. Special Situations

Vacant or Unoccupied Properties

Vacant, unattended, deteriorating property does not promote orderly community development. Buildings that are vacant or unoccupied and open and accessible to unauthorized persons are not insurable under this plan.

The vast majority of arson losses occur in vacant or unoccupied buildings. Our losses are due to vandalism by juveniles, removal of building fixtures by thieves, abuse by vagrants, squatters, or drug dealers, and liquidation of assets by disappointed investors. The longer a property is vacant, the greater the likelihood of loss.

Policy conditions require notice to the Association if a property is vacant at inception, or becomes vacant during the policy term. A Supplemental Application is required, and coverage does not begin until after approval by the underwriter.

New “ground up” construction is not considered vacant during the period of construction.

Renovation or remodeling of an existing building is considered vacant unless it is occupied by the insured during the renovation period.

Seasonal property is not considered vacant during the normal period of seasonal unoccupancy.

Review the “Standards for the Protection of Vacant or Unoccupied Properties” to assure the risk is properly protected from unauthorized access.

Standards For The Protection of Vacant or Unoccupied Properties

A. Openings other than door

1. All accessible openings (including basement windows) shall be protected by either of the following methods:
 - (a) All accessible openings shall be boarded with ½ -inch plywood nailed to the outside for the opening with 10 penny or heavier nails every 4 inches on centers or
 - (b) All accessible openings shall be boarded with ½-inch exterior plywood placed on the outside of the structure. It shall be held flush to the window frame by ½-inch carriage bolts (with the nut on the inside of the structure) fastened through two 2" x 4" located on the inside of the structure, one found at the top and one at the bottom of the window (as indicated on the drawing provided). The 2" x 4" shall extend a minimum of 2-inches onto the frame area. Bolts shall be firmly fastened.
2. All inaccessible openings need not be protected in the above manner, but must be protected to keep the elements from damaging the interior of the building. The following openings shall be considered as inaccessible:
 - (a) Openings more than 14 feet above the ground.
 - (b) Openings more than 14 feet above roof of adjacent or adjoining building.
 - (c) Openings greater than 14 feet from directly or diagonally opposite windows, fire escapes, roofs, etc.
 - (d) Openings greater than 4 feet from fire escapes.

B. Doors

1. All wood panel, wood glass panel and metal glass panel doors shall be covered with ½-inch plywood nailed or bolted to the outside of the door every 4 inches on centers.

Note: Doors of construction other than mentioned above shall be referred to NJIUA to determine necessary protection.
2. (a) All doors (with the exception of one door which is to be used for authorized entry to the interior of the building) shall be secured on the interior with flat iron cross bars with brackets installed in such a manner as to prevent the door from being opened from the outside. Crossbars are to be made of 1¾ inch by ¾ inch flat iron bar and brackets of 1½ inch by ¾ inch iron.
 - (b) Door, which is to be used for authorized entry, shall be double padlocked. One padlock to be placed 2 feet from top of the door, and one padlock to be placed 2 feet from the bottom of the door.

Note: The steel bar and staple of the hasp shall be secured with recessed screws in such a manner so that the screws are concealed when the hasp is closed.

DIAGRAM FOR THE PROTECTION OF WINDOWS OF VACANT PROPERTY

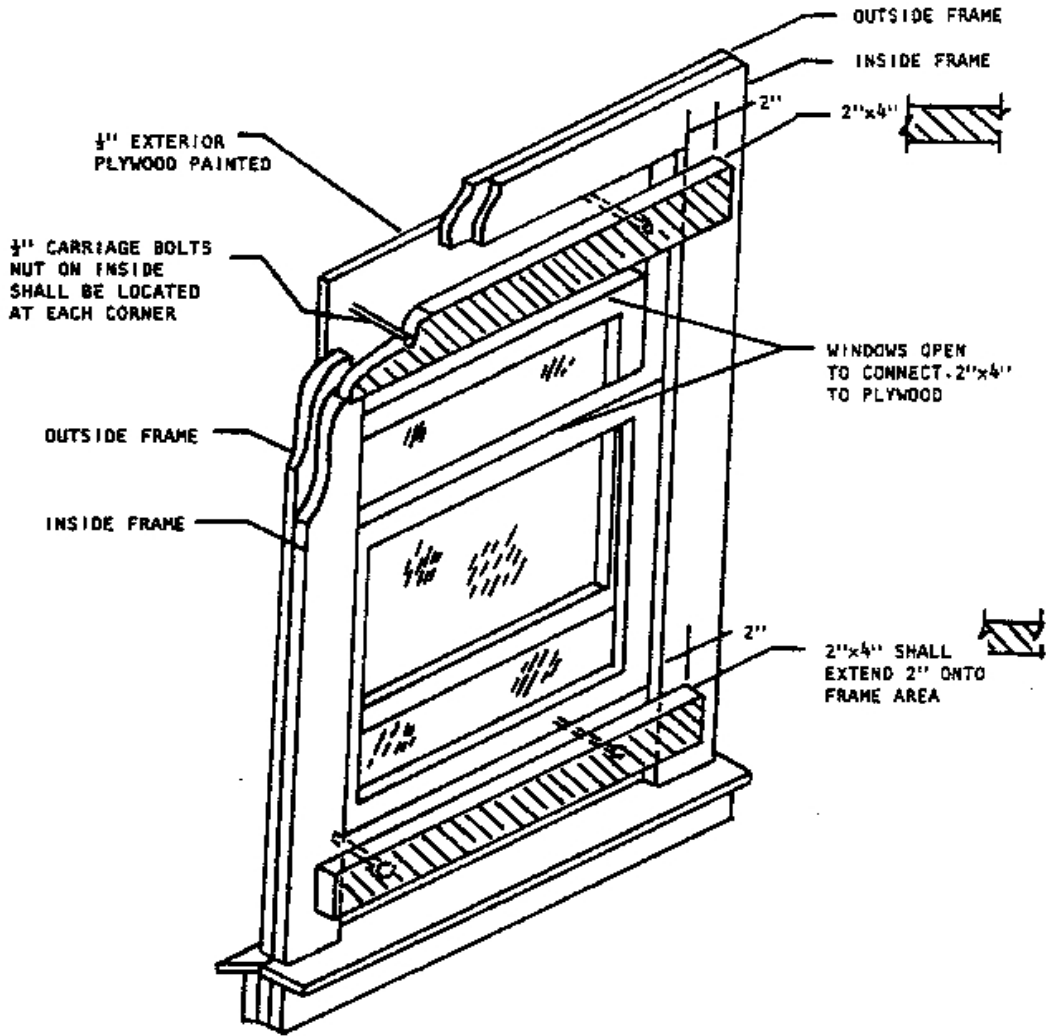

INTERIOR VIEW

(Und. - VACANT-2 (Oct 1986)

1-1-88

Fungi, Wet or Dry Rot or Bacteria Coverage Dwelling Fire

There is a \$10,000 base limit included in the DP1 and DP2 policy form regardless of the number of locations. For coverage to apply the fungi, wet rot, dry rot or bacteria has to result from a covered cause of loss.

There are 2 optional limits available for an additional premium.

For DP1 the insured can select a limit of \$25,000 for an additional premium of \$16.00 or a limit of \$50,000 for an additional premium of \$27.00. For DP2 the \$25,000 premium is \$44.00 and \$74.00 for \$50,000.

Commercial Standard Property Business

There is a \$15,000 base limit included in the policy regardless of the number of locations on a policy. The insured can purchase additional limits on a per policy basis or per location basis.

The fungi, wet rot, dry rot or bacteria must result from a covered peril for coverage to apply.

New Jersey is a Standard Fire Policy state therefore; the coverage limitations for both lines of business are not applicable if the fungi, wet rot, dry rot or bacteria is a result of a fire loss.

Coverage for Certified Acts of Terrorism

Coverage is offered on all commercial lines standard property business for an additional premium of 6% of the total Group 1 and Group 2 premium for building and contents.

An insured can reject the offer of terrorism coverage. However, New Jersey is a Standard Fire Policy state and there will be a premium charge of 3.6% of the Group 1 premium only for Certified Acts Of Terrorism that result from fire.

Hurricane Damage Mitigation Certification

Policyholder Instructions

The purpose of this form is to allow policyholders in the 92 coastal area zip codes to request a reduction in the hurricane deductible applicable to their insured property. To do so, complete pages 3 and 4 of this form, enclose the required documentation, and mail all information to:

New Jersey Insurance Underwriting Association
744 Broad Street
Newark, NJ 07102

Specific instructions for each question on the form are as follows:

1. The BOCA National Building Code of 1996 and the CABO 1 and 2 Family Dwelling Code of 1995 were adopted in New Jersey as of January 6, 1999. Both require roof construction that should withstand 85 mph winds. Therefore, if your property was built after 1-6-99 it is presumed to comply with this guideline. If your roof was totally remodeled, not just re-shingled, to comply with building codes effective 1-6-99, it is also presumed to comply with this guideline. Check either item a or b as appropriate, and provide receipts or contract. If your property was built prior to 1-6-99, and the roof has not yet been updated, check c, and continue.
2. If your home is not built with wooden roof trusses, check item c, and continue to next question. The BOCA National Building Code of 1993 and the CABO Code of 1992 were adopted in New Jersey on November 1, 1993. Therefore, if your property has roof trusses, and was built after 11-1-93, it is presumed to comply with this guideline. If your property was built before 11-1-93, and you subsequently installed hurricane clips, check item b, and provide receipts or contract for work completed.
3. Damage is generally much more severe if wind and water reach the interior of your property. All exterior glass must be protected from breakage by flying debris. If your property is equipped with metal or solid wood panel shutters, which will be closed over all glass before a storm, check item a. If you will fasten plywood over all glass before a storm, check item b. If your property is equipped with impact resistant glass material (labeled or listed in compliance with SSTD - 12-97) check item c, and provide receipts or contract for installation.

HD 99 03 (03-99)

Hurricane Damage Mitigation Certification

Policyholder Instructions

4. If your property does not have overhead garage doors, check d and continue to next question. If your overhead garage door is labeled to withstand winds of 85 mph, check a, and provide copy of label or literature. If you have equipped both the door and tracks with bracing or reinforcing, check b and c. (Note enclosed diagram)
5. To prevent wind and water from reaching the interior of your property, all exterior doors must remain securely closed. If exterior doors are equipped with three or more hinges, check a. If all exterior doors are equipped with either dead bolt locks, or door pins that extend at least ½”, check b.
6. Provide copies of any documentation to substantiate your request for a lower deductible. If you do not have manufacturers literature, receipts, or contracts; a written home inspection report clearly stating which loss mitigation features are present, is acceptable. The report should be prepared and signed by a licensed, architect, engineer, or home inspection firm.
7. Read the certification statements, sign and date the form. Mail to:

New Jersey Insurance Underwriting Association
744 Broad Street
Newark, NJ 07102

HD 99 03 (03-99)

NEW JERSEY INSURANCE UNDERWRITING ASSOCIATION

Hurricane Damage Mitigation Certification

Named Insured: _____ Policy Number _____

Location of Insured Property

Number and Street

City _____ NJ Zip Code _____

Telephone Number: () _____ daytime () _____

This property has the following features:

1. The roof including roof supports, roof decking and roof shingles are installed to withstand a wind speed of 85 miles per hour.
 - a) _____ Yes - house built after 1/6/99.
 - b) _____ Yes - older house, roof remodeled after 1/6/99. (Attach receipts or contract.)
 - c) _____ Not applicable - roof built prior to 1/6/99, or is not a shingle roof.

2. The wooden roof trusses are connected to the top plate of the exterior walls by metal hurricane straps, clips, or other appropriate mechanical means (simple nailing is not appropriate).
 - a) _____ Yes - house built after 11/1/93.
 - b) _____ Yes - trusses are properly connected. (Attach receipts or contract.)
 - c) _____ Not applicable - house not built with trusses.

3. All windows, skylights, and patio doors are protected against flying debris caused by hurricane winds.
 - a) _____ Yes - the house has metal or wood panel shutters, and they will be closed before a storm.
 - b) _____ Yes - all windows will be covered with 3/4" exterior grade plywood before a storm.
 - c) _____ Yes - all doors, windows, and skylights are made of impact resistant (labeled or listed) material.

HD 99 03 (03-99)

4. All overhead garage doors and tracks are reinforced.
- a) _____ Yes - overhead garage doors are labeled to withstand 85 mph. (Attach copy.)
 - b) _____ Yes - overhead garage doors are braced.
 - c) _____ Yes - overhead garage door tracks are reinforced.
 - d) _____ Not Applicable - no overhead garage door.
5. All exterior doors are fastened to door jambs with 3 or more hinges, and have dead bolts or door pins that project a minimum of ½”.
- a) _____ Yes - exterior doors have 3 or more hinges.
 - b) _____ Yes - exterior doors have dead bolts or door pins that project a minimum ½”.

6. Documentation and Certification Required

To substantiate the existence of the loss mitigation features indicated above, I have enclosed the following:

- _____ Manufacturers labels or literature.
- _____ Receipts for items purchased.
- _____ Contractors bills for labor and materials.
- _____ Written home inspection report prepared by licensed firm.

I certify that the property described above contains the indicated hurricane damage mitigation features. I understand that if a hurricane loss occurs, the claim adjuster will confirm their existence. This request for a decrease in my hurricane deductible is subject to approval by the New Jersey Insurance Underwriting Association. I realize that any false or misleading information will be considered lack of good faith on my part and will void the decrease in the hurricane deductible.

Signature of Insured: _____

Date: _____

H. WindMAP Windstorm Market Assistance Program (WindMAP) is a voluntary industry program created to assist homeowners in New Jersey's coastal areas (92 specific zip codes) to obtain insurance. The WindMAP represents a group of insurers who have agreed to give special underwriting consideration to those homeowners unable to obtain insurance in the voluntary market. Producers that represent WindMAP participating companies should contact their carrier about writing business in the coastal area. Producers that do not have access to WindMAP participating companies may apply through the rotation process portion of the program, which is administered by the New Jersey Insurance Underwriting Association.

How to Apply to WindMAP Rotation Process

1. Complete either the ACORD 80 Homeowners application, or the ACORD 84 Dwelling Fire application (if occupancy is seasonal, rented to tenant, mobile home, or owned by partnership or corporate entity other than a natural person or husband/wife).
2. Complete the WindMAP Supplemental Application, and provide as much detail as possible in answer to all **Underwriting Questions**.
3. Attach a copy of the non-renewal or cancellation notice needed in **Eligibility Question 1**.
4. Attach evidence of sale or other documentation of transfer needed in **Eligibility Question 2**.
5. Attach copy of FAIR Plan policy declarations page needed in **Eligibility Question 3**.
6. Attach copies of all declination notices received from WindMAP participating companies needed in **Eligibility Question 5**.
7. Producer and applicant must sign and date the ACORD form, and the applicant must sign and date the Supplemental Application.
8. Mail all submission materials to the following address:

**New Jersey WindMAP
P.O. Box 32340
Newark, NJ 07102**
9. Do not send money. Coverage is not bound. Insurance does not exist until the insurer's application and underwriting procedures are completed and a binder is issued.
10. You will receive an acknowledgment that your application was accepted for processing.

WindMAP

COASTAL REGION ZIP CODES

07002	07715	07753	08202	08405	08750
07008	07716	07755	08203	08406	08751
07036	07717	07756	08204	08411	08752
07064	07718	07757	08212	08721	08753
07077	07719	07758	08223	08723	08754
07201	07720	07760	08226	08724	08755
07202	07721	07762	08230	08730	08756
07206	07723	07764	08243	08731	08757
07302	07730	08005	08247	08732	08758
07304	07732	08006	08248	08734	08832
07305	07734	08008	08260	08735	08861
07306	07735	08050	08400	08736	08862
07709	07737	08087	08401	08738	08878
07711	07740	08092	08402	08739	08879
07712	07748		08403	08740	
07713	07750		08404	08742	

92 Coastal ZIP Codes referred to in Section I.9 of WindMAP Plan of Operation

WindMAP

Participating Companies

<u>COMPANY NAME</u>	<u>PHONE NUMBER</u>	<u>FAX NUMBER</u>
Travelers of New Jersey	(800) 842-0169 X925	(609) 985-0443
ACE USA (CIGNA)	(302) 467-6043	(800) 807-3011
CONTINENTAL OF NJ/CNA INS.	(610) 396-3810	(877) 570-0023
MERCHANTS INS. GROUP	(800) 462-1077X3019	(716) 849-3303
SELECTIVE INS. GROUP	(973) 948-1630	(973) 948-2768
LIBERTY MUTUAL GROUP	(800) 233-8481X309	(570) 323-0654
AMICA MUT. INS. CO.	800) 622-6422X4468	(401) 334-1493
ALLSTATE INS COMPANY	(908) 252-5053	(908) 252-5153
STATE FARM INS. COMPANIES	(973) 739-5376	(973) 305-6446
HighPoint Insurance Company	(732) 946-6039	(732) 946-6217
NJ RE-INS. COMPANY / NJM	(609) 883-1300X2001	(609) 882-1806
USAA	(210) 498-2866	(210) 498-1806
FARMERS MUT. FIRE INS. CO. OF	(856) 935-1851X132	(856) 935-7955
FARMERS' MUT. FIRE ASSUR.	(908) 782-4120	(908) 782-6168
CUMBERLAND MUT. FIRE INS.	(856) 451-4050	(856) 455-8468
THE ANDOVER COMPANIES	(800) 225-0770X220	(800) 323-5112
THE PHILA. CONTRIB. INS. CO.	(215) 627-1752X1258	(215) 627-5354
AEGIS SECURITY INS. CO.	(800) 233-2160	(717) 657-0340
FRANKLIN MUTUAL INS. CO.	(973) 948-3120X8241	(973) 948-7190
HANOVER INS. COMPANIES	(732) 457-0577X2278	(732) 457-9564
KEYSTONE INS. CO. OF NJ	(215) 864-5183	(215) 568-1153
ONE BEACON INS.	(908) 766-8724	(973) 593-3279

I. Frequently Asked Questions

- **Can producers bind coverage?**
No. Producers cannot bind coverage. Refer to Section C, General Rules to determine when coverage begins.
- **How long does it take to issue a policy?**
A policy can usually be issued within 10 business days, following receipt of all required information and payment of full net premium.
- **Are policies automatically renewed or continued?**
No. By statute, we are limited to a one-year policy. If coverage cannot be obtained in the voluntary market, the policy can be renewed by sending the premium payment and the payment invoice to the Association on or before the expiration date.
- **How long does it take to return overpayment of commission?**
Overpayment checks take approximately 3-5 weeks to be issued. Producers are encouraged to remit net premium.
- **Are rates for dwelling business available to producers?**
Yes. Dwelling rates are available by contacting EIO at (609) 267-1992.
- **Is liability coverage available through the Association?**
No. The Association is authorized to write only essential property insurance.

Is replacement cost coverage available through the Association?

Yes, if the applicant qualifies for DP 2 Broad Form coverage and the amount of insurance carried is at least 80% of the estimated replacement cost value. The DP 1 policy form provides ACV coverage only. Producers are encouraged to discuss values with their customer. Refer to Section C. "Actual Cash Value" for guidance.

- **Are values automatically adjusted for inflation or changes in building costs?**
Yes, on DP 2 policies since there is replacement cost coverage and no for DP1 policies because the policy form is ACV only, and the insured or

producer must adjust values as necessary.

- **What documentation is needed to support value changes?**
Inflation related adjustments at renewal do not require any supporting documentation. For large or mid-term adjustments, mortgage company requests, documentation of current market value, evidence of assessed value, or copies of contracts or bills for recent improvements are required to support value requested.

- **Can more than one location be insured on the same policy?**
Yes. A policy can include more than one location if all properties are eligible for the same line of business, dwelling or commercial.

- **Is the FAIR Plan required to accept all applications?**
*No. Refer to **Section B. Mission Statement**, and **Section C. General Rules “Properties Not Insurable”**.*

- **What if the insured does not want the terrorism coverage offered?**
If terrorism coverage is not desired, it can be rejected. A Terrorism Disclosure Form will be sent with each new business and renewal quote. If the insured does not want the coverage, the signed rejection section is completed and returned with the premium payment.

- **How do I report a claim?**
*All claims must be reported to NJIUA at: 744 Broad Street
Newark, NJ 07102
Phone: (973) 622-3838
Fax: (973) 645-0269
Toll Free 1-866-654-7526
Internet- see website- Claims section.*
*Please use the ACORD Property Loss Notice for reporting claims.
Fax submission of the ACORD form is also acceptable.*

Producers cannot assign claims to adjusters.